

HANDY PENDANT

HP-V Model



Handy Model

- Reasonable Cost vs. Performance.
- Fit To Hand Holding.



Model

HP-V -2 -P - -00E

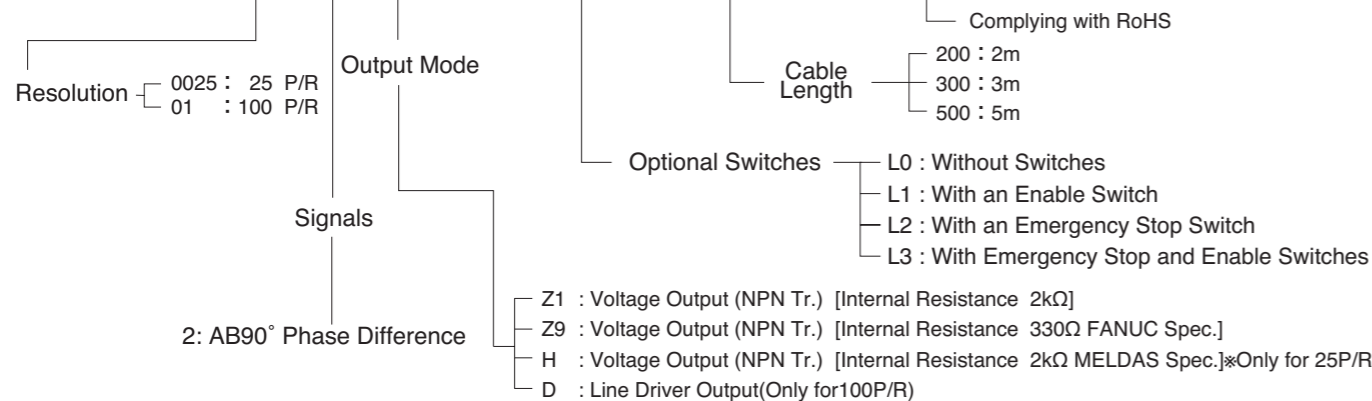

External Dimension

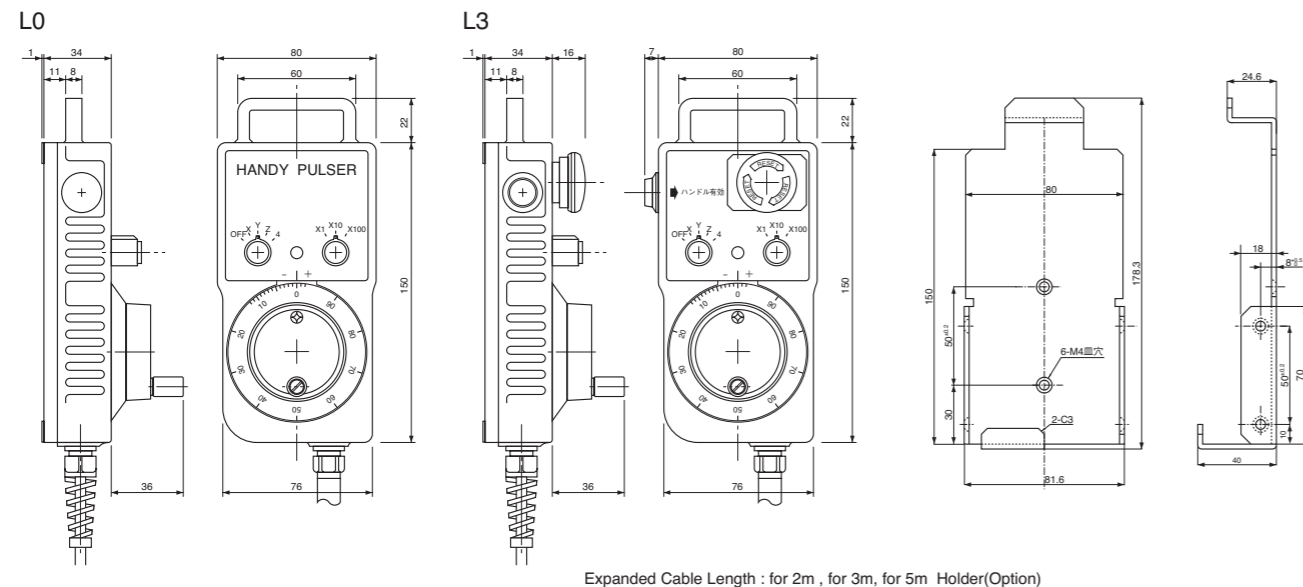

Expanded Cable Length : for 2m , for 3m, for 5m Holder(Optional)

Output Circuit

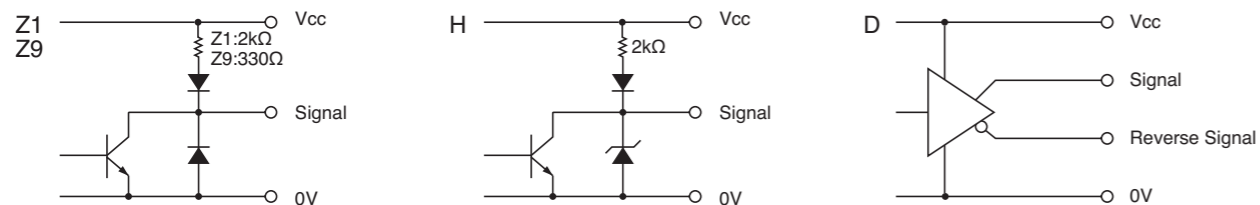

Electrical Spec

Manual Pulse Generator

TYPE	Z1	Z9	H	D
Power Supply(Vcc)	DC+4.5V~13.2V	DC5V±10%	DC12V±10%	DC5V±5%
Current Consumption	60mA Max	80mA Max	60mA Max	150mA Max
Resolution	100P/R · 25P/R			100P/R
Output Voltage	"H"	Vcc-1V Min	+5V±10%	2.5V Min
	"L" *1	0.5V Max		
Maximum Frequency Response	5kHz			
Rise & Fall Time	1 μs Max		1.5 μs Max	200ns Max
Maximum Sink Current	20 mA			

*1) at Maximum Sink Current

Switches

Rotary Switches

Contact Rating	0.4 VA	Maximum Voltage	25 V
Current	0.1~50 mA		

Enable Switch

*1 Contact Rating	With AC Load Resistance	AC220V 0.5A , AC110V 1.0A
	With DC Load Resistance	DC 24V 1.0A

Emergency Stop Switch

*1 Contact Rating	With AC Load Resistance	AC250V 0.5A , AC125V 1.0A
	With DC Load Resistance	DC 30V 1.0A

*1Min. Load DC 5V 1mA

Wave Form

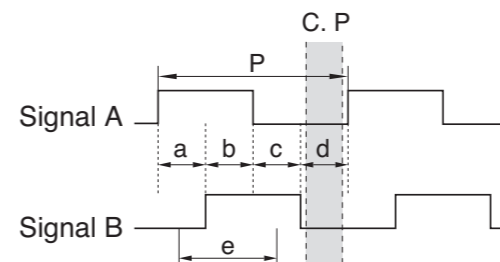

$$P = \frac{1}{\text{Resolution}}$$

$$a, b, c, d = \frac{P}{4} \pm \frac{P}{6}$$

Wave Ratio (Duty): 50 ± 25(%)

C. P = Click Point

For mode 25P/R click point is at each position of a,b,c,d.

*1) Inverted Output is available for 2D type.

*2) Point "e" is recommended as the system switching timing.

Electrical Connections

L3 Spec.

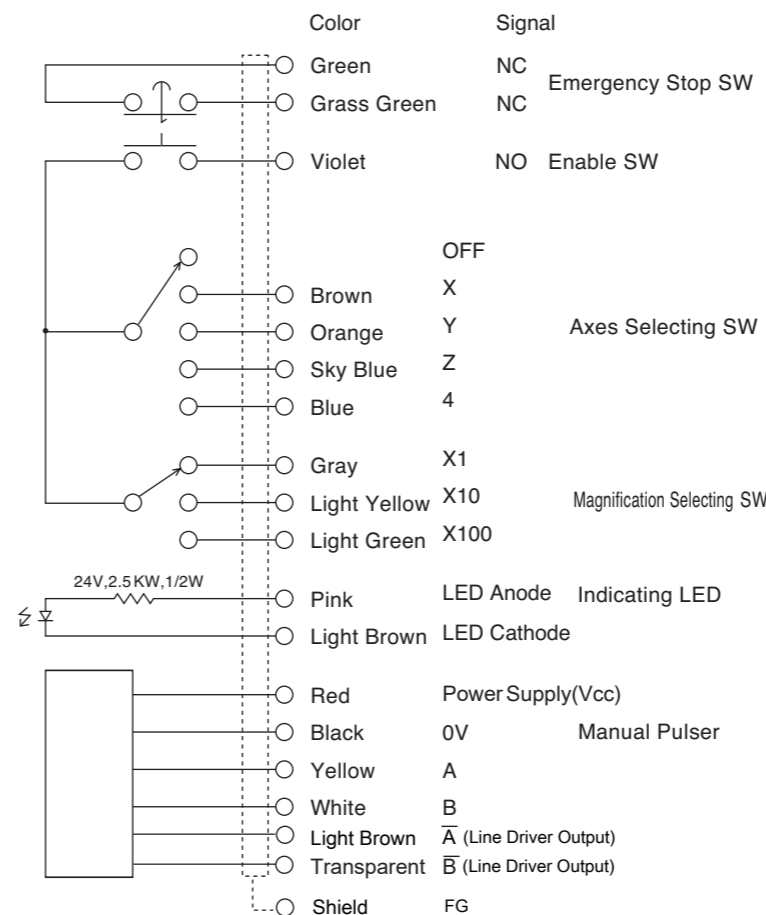

Mechanical Spec

Starting Torque	1.96×10 ⁻² N·m~5.88×10 ⁻² N·m	
Shaft Loading	Thrust	9.8N
	Radial	19.6N
Maximum Permissible Speed	200min ⁻¹	
Net Weight(Without Cable)	500g Max	

Environmental Spec

Operating Temperature	-10°C~+60°C
Storage Temperature	-20°C~+70°C
Humidity	RH 85% Max No Condensation
Vibration	10~55 Hz / 1.5mm X,Y,Z Each 2h
Shock	490m/s ² , 11ms X, Y, Z Each 3 times
Ingress Protection	IP65(for Box)